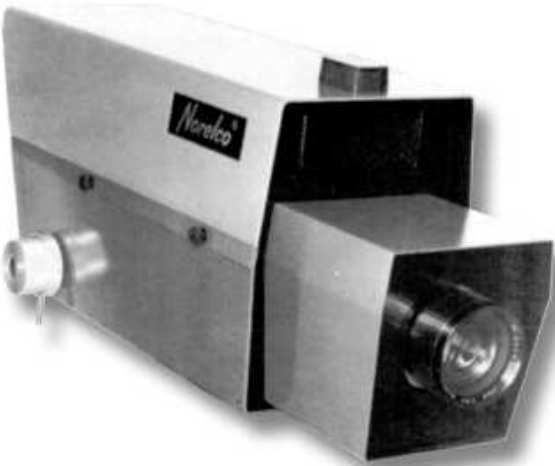

European and American Television Cameras

	Make	Norelco
	Model	VF-150
	Country	USA
	Camera Type : Studio Monochrome	
	Camera Description : Simple low budget design with wrap over case, viewfinder offset to one side.	

Data

Tube details	1" Vidicon XQ-1030
Lens details	Zoom
Sig. to Noise	38dB below 1V p-p at normal gain
Sensitivity	
Resolution	600 lines
Viewfinder	5" fixed
Camera cable	none
Power supply	34W at 117V AC 50/60Hz.

Data

Line standards	525/60 625/50 int. mod. option
Colour standards	Monochrome
Drives or locking	H&V + Sync on camera BNCs
Weight *	25Lbs.
Colours	
Dimensions *	305H x 273W x 518L mm.
Date introduced	~~1972 ??

*Excluding Lens & Viewfinder

Associated equipment

Self-contained camera.

Features

Automatic operation with; stable blacklevel control; peak white limiter; white signal compression; beamcurrent stabilization. Internal 2:1 interlace or external H & V drives. Separate mesh vidicon option.

General description

Choice of zoom lenses with ranges of 25-100mm. to 15 –150mm.
There was an internal shaft drive for the lens controls.

References

Product brochure

Photo Reference

History

Notes

Used By